

Hex 6 A

EN

No. 029951 • rev. 2.0 • 27.09.2005

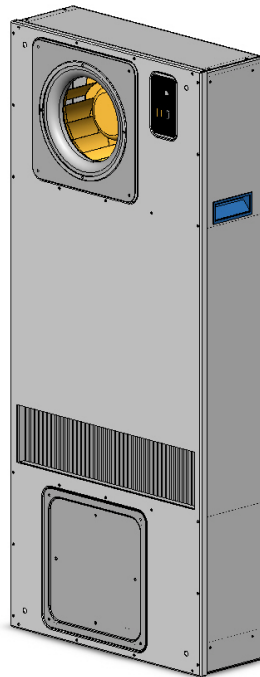

Der tages forbehold for trykfejl og ændringer
Dantherm can accept no responsibility for possible errors and changes
Irrtümer und Änderungen vorbehalten
Dantherm n'assume aucune responsabilité pour erreurs et modifications éventuelles

Introduction

Overview

Introduction This is the service manual for the Dantherm HEX 6 A unit.
The below table of contents gives an overview of the main sections.
Please refer to the complete table of content for further information about the sections.

Serial number This manual covers units with serial numbers equal or higher than:
xxxxxx0764740

Warning **It is the responsibility of the operator to read and understand this service manual and other information provided and to use the correct operating procedures. Heat exchangers should only be operated by qualified (trained) personnel and repair of cooling circuit and/or electrical system done only by skilled service people. Failure to do so can result in personal injury or equipment damage.**
Read the entire manual before the initial start-up of the heat exchanger. It is important to know the correct operating procedures for the heat exchanger and all safety precautions to prevent the possibility of property damage and/or personal injury.

Table of contents This service manual covers the following main topics:

Topic	See page
Introduction	Next page
Product and functional description	5
Service guide	7
Technical information	14

General information

Introduction This section gives the general information about this service manual and about the unit.

Manual, part number Part number of this service manual is 029951.

Target group The target group for this service manual is the:

- Users of the unit
- Technicians who install and maintain the unit

Copyright Copying of this service manual, or part of it, is forbidden without prior written permission from Dantherm.

Reservations Dantherm reserves the right to make changes and improvements to the product and the service manual at any time without prior notice or obligation.

EC-Declaration of Conformity Dantherm A/S, Marienlystvej 65, DK-7800 Skive hereby declare that the units mentioned below:



HEX 6 A – product no. 352926:

is in conformity with the following directives:

98/37/EEC	Directive on the safety of machines
73/23/EEC	Low Voltage Directive
89/336/EEC	EMC Directive
97/23/EEC	Pressure Equipment Directive

- and are manufactured in conformity with the following standards:

EN 292	Machine Safety
EN 60 335-1	Low voltage
EN 60 335-2	Low voltage
EN 61 000-2	Immunity
EN 61 000-3	Emission

Skive, 20.09.2005

Managing director Per Albæk

Project manager Lars Nørgaard

Product and functional description

Introduction

This section gives all necessary information about the product and its functions.

Control system

The HEX 6 A is controlled via a controller that controls the speed of the fans.

The key features of the controller are:

- Temperature sensor
- Set points
- Alarm output
- Power

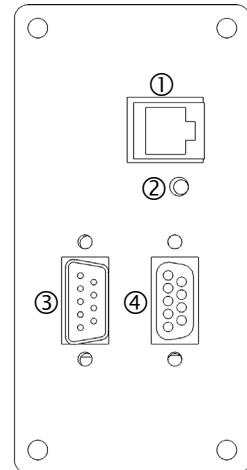

Part	Function
①	RS 232 – connector for <ul style="list-style-type: none"> • factory testing or • further information from the controller
②	Alarm LED, see page 7
③	9 Sub-D power plug – male
④	9 Sub-D plug – female – When the plug is removed a test of the fans can be run. The fans will run maximum speed, when the plug is removed. NB: The plug should always be mounted during normal operation

Temperature sensor

The temperature sensor is an on board sensor, placed on the controller.

Continued overleaf

Product and functional description, *continued*

Set points at increasing temperatures

The following set points are according to the control strategy when the temperature is increasing:

Description	Internal temperature	Fan speed
Internal fan	Below 20 °C 20 °C – 30 °C Between 30 °C – 50 °C Over 50 °C	Off (0) Low (1100) Between low and high (1100-1920) High (1920)
External fan	Below 30 °C 30 °C – 35 °C Between 35 – 55 °C Over 55 °C	Off (0) Low (1100) Between low and high (1100-1850) High (1850)

Set points at decreasing temperatures

The following set points are according to the control strategy when the temperature is decreasing:

Description	Internal temperature	Fan speed
Internal fan	Over 50 °C Between 50 – 30 °C 30 °C – 18 °C Below 18 °C	High (1920) Between high and low (1920-1100) Low (1100) Off (0)
External fan	Over 55 °C Between 55 – 35 °C 35 °C – 28 °C Below 28 °C	High (1850) Between high and low (1850-1100) Low (1100) Off (0)

Two separate air flows

The two airflows (internal/external) are totally separated. The external air is only used to cool down the internal air via the counter flow recuperator. The air flows are never mixed.

Internal air flow

The warm internal air is sucked from the base station into the internal fan at the top of the HEX 6 A and let through the recuperator, where it is cooled down. After the cooling in the recuperator the air is let back into the base station.

External air flow

The cold external air is sucked into the external fan at the bottom of the HEX 6 A and let through the recuperator, where it is cooling down the internal air. After having passed through the recuperator the air is let back to the external environment at the top of the unit.

Service guide

Overview

Introduction This section gives all relevant information about servicing, spare parts and faultfinding.

Preventive maintenance The recommended preventive maintenance intervals should not exceed 6 months.

Cleaning/-inspection The unit needs to be cleaned according to the recommended preventive maintenance intervals of 6 months.
Access to the internal and the external fans is possible through the inspection/service lids.
The core can be internally cleaned by accessing the service lids.

Fault finding Operating errors may occur. These possible faults/problems are listed in column one in the below table.
The middle column shows the possible cause for the fault.
A possible solution of the problem is to be found in column three.

Problem	Cause	Solution
The red LED illuminates constantly	Too high temperature in the shelter, above 70 °C or a fan failure	Replace the fan
The red LED is flashing	The on board sensor has been disconnected/shorted	Replace the controller
The internal fan runs at low speed	The temperature in the shelter is below 20 °C	This is due to the control strategy
The external fan runs at low speed	The temperature in the shelter is below 30 °C	This is due to the control strategy

Contents This section contains the following topics:

Topic	See page
How to replace the control panel	next page
How to replace the internal fan	10
How to replace the external fan	12

How to replace the control panel

Product description

The control board controls the unit based on inputs from the onboard temperature sensors.

When to replace

The control board only needs to be replaced when it is faulty.

Part number

The control board can be ordered under part number 296168.

Tools

Make sure you have the following tools available before you start:

- Torx 20 screw driver
 - Straight slot screw driver for power plug
-

Caution!

- Only trained and certified technicians are allowed to replace parts
 - Switch off the DC supply before working on the unit
 - Make sure that all work has been performed before switching on the power again
-

Illustration

This drawing illustrates the control board and where it is placed in the unit:

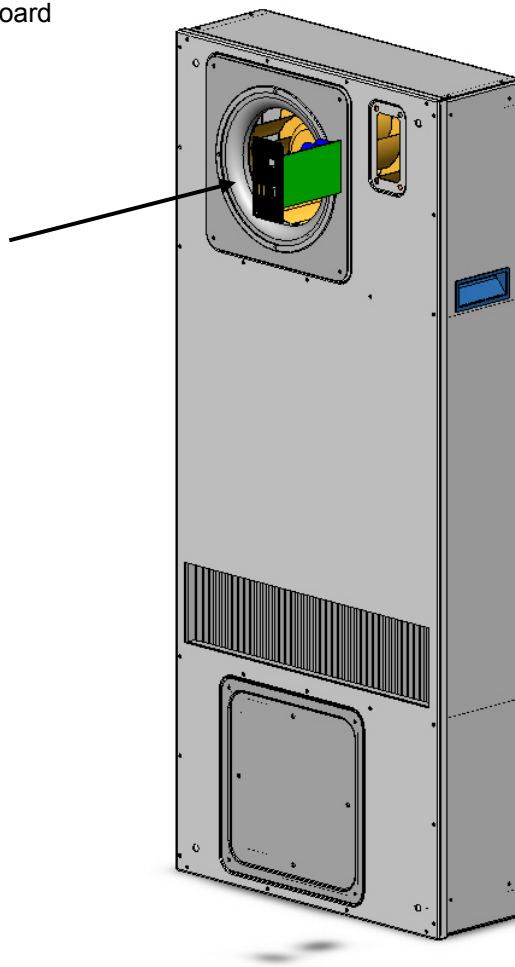

Continued overleaf

How to replace the control panel, *continued*

Procedure

Follow these steps to replace the control board:

Step	Action
1	Switch off all the power to the unit
2	Loosen the two straight slot screws on the power plug and remove the power plug from the controller
3	Remove the 4 torx 20 screws that hold the controller
4	Take out the controller by turning it to the left
5	Remove the two 4-way multi plugs from the controller
6	Mount a new controller by following step 2 to 5 reversed and in opposite order
7	Connect the power Result: The test program runs through all functions. Check that the unit does not come out with an alarm signal. In case of an alarm signal, please see page 5

How to replace the internal fan

When to replace The internal fan only needs to be replaced when it is faulty or as a part of a long time replacement plan, e.g. after approximately 5 years.

Part number The internal fan can be ordered under part number 296169.

Tools Make sure you have the following tools available before you start:

- Torx 20 screw driver

Caution!

- Only trained and certified technicians are allowed to replace parts
- Switch of the DC supply before working on the unit
- Make sure that all work has been performed before switching on the power again

Illustration This drawing illustrates the internal fan and where the fan is placed in the unit:

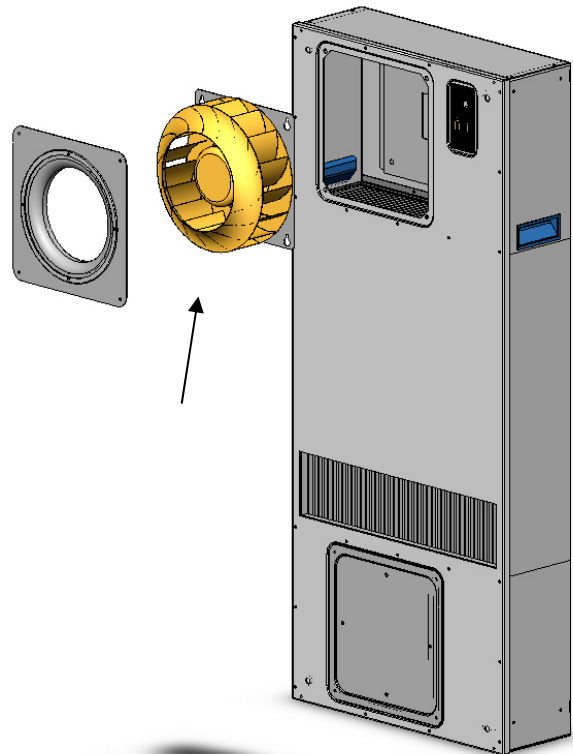

Continued overleaf

How to replace the internal fan, *continued*

Procedure

Follow these steps to replace the internal fan:

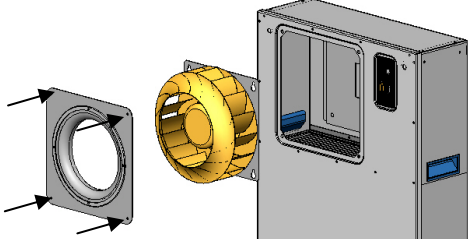
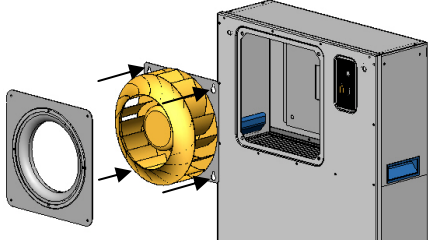
Step	Action
1	Switch of all the power to the unit
2	Remove the 4 torx 20 screws that holds the front cover plate and remove the front cover plate 
3	Loosen (do not unscrew) the 4 torx 20 screws that hold the fan and lift off the fan 
4	Take out the fan
5	Disconnect the 4-way multi plugs from the fan
6	Mount a new internal fan by following step 2 to 5 reversed and in opposite order
7	Connect the power Result: The test program runs through all functions. Check that the unit does not come out with an alarm signal. In case of an alarm signal, please see page 5

How to replace the external fan

When to replace The external fan only needs to be replaced when they are faulty or as a part of a long time replacement plan, e.g. after approximately 5 years.

Part number The external fan can be ordered under part number 296170.

Tools Make sure you have the following tools available before you start:

- Torx 20 screwdriver

Caution!

- Only trained and certified technicians are allowed to replace parts
- Switch of the DC supply before working on the unit
- Make sure that all work has been performed before switching on the power again

Illustration This drawing illustrates the external fan and where the fan is placed in the unit:

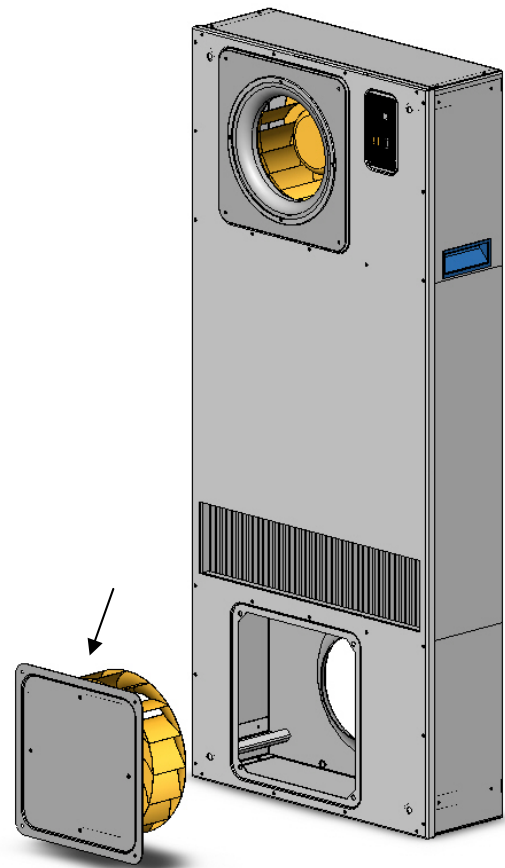

Continued overleaf

How to replace the external fan, *continued*

Procedure

Follow these steps to replace the external fan:

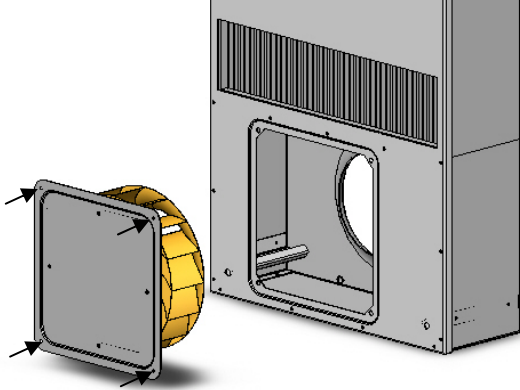
Step	Action
1	Switch of all the power to the unit
2	Remove the 4 torx 20 screws that holds the front cover plate and remove the front cover plate 
3	Remove the 4 torx 20 screws that hold the fan
4	Take out the fan
5	Disconnect the 4-way multi plugs from the fan
6	Mount a new internal fan by following step 2 to 6 reversed and in opposite order
7	Connect the power Result: The test program runs through all functions. Check that the unit does not come out with an alarm signal. In case of an alarm signal, please see page 5

Technical information

Overview

Contents

This section contains the following topics:

Topic	See page
Technical data	next page
Wiring diagram	16

Technical data

Data

These are the technical data for the HEX 6 A:

Specification	Unit	Value
Dimensions (H × W × D)	mm	1050 × 450 × 150
Maximum ambient temperature	°C	45
Minimum ambient temperature	°C	÷ 45
Maximum cabinet return temperature	°C	70
Specific cooling capacity incl. solar	W/K	90
Voltage supply	V DC	52 (42-56)
Power consumption (48 V DC)	W	120
Sound pressure as stand alone	dB(A)	64
Air flow, internal	m ³ /h	420
Air flow, external	m ³ /h	420
Weight	kg	18

Dimensions

This illustrates the dimensions of the unit:

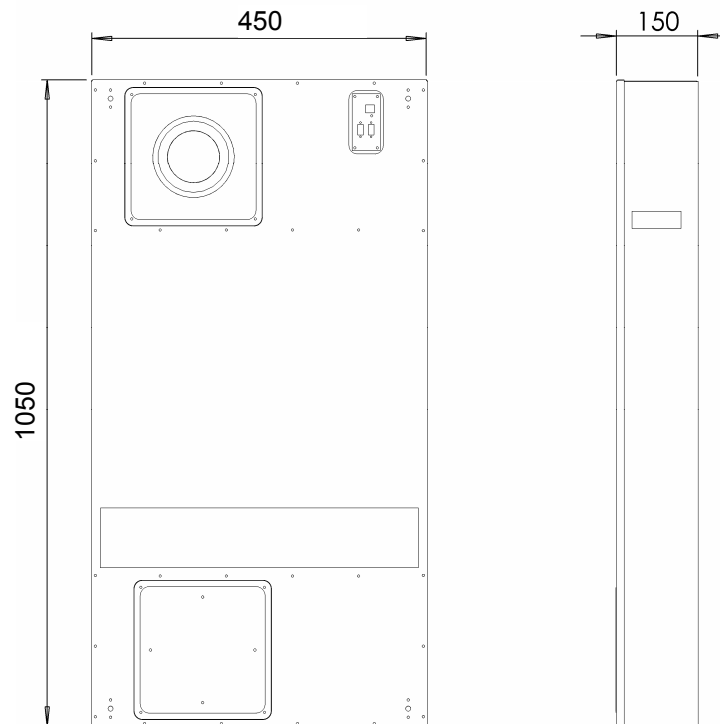

Wiring diagram

Diagram

This shows the electrical wiring diagram for HEX 6 A:

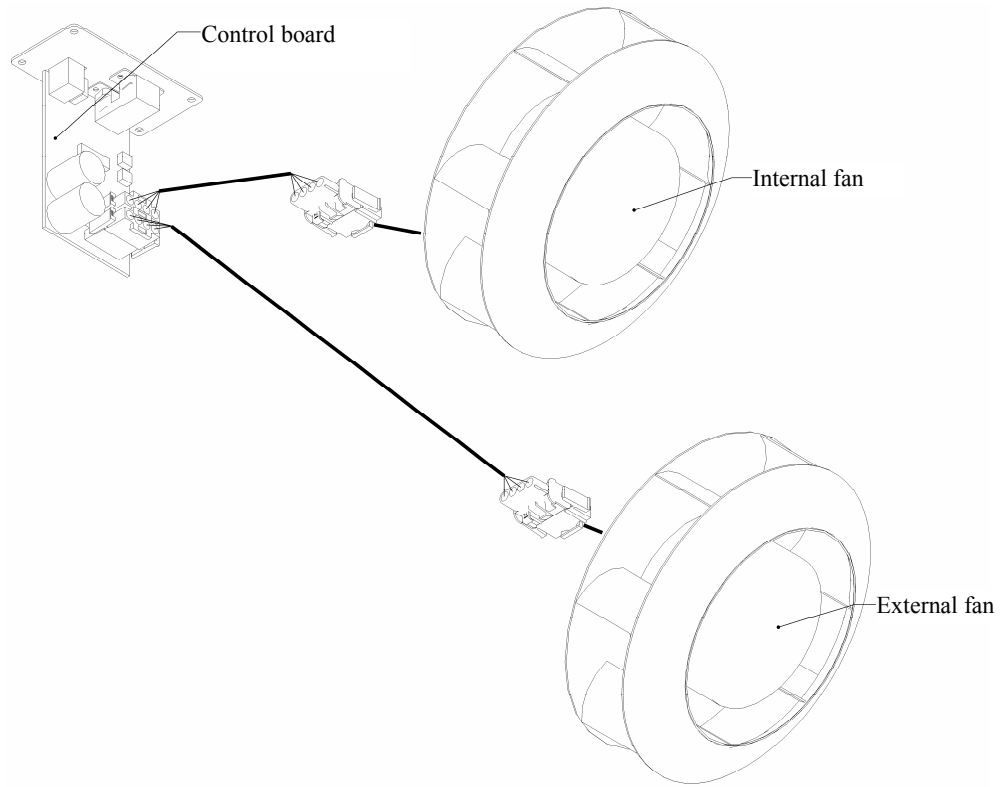

Index

A

air flows 6

C

CE-Declaration of Conformity 4

cleaning 7

copyright 4

D

dimension of the unit 15

E

external air flow 6

F

fault finding 7

functional description 5

I

internal air flow 6

P

part number

 manual 4

preventive maintenance 7

product description 5

R

reservations 4

S

service guide 7

set points 6

spare parts

 control panel 8

 external fan 12

 internal fan 10

T

target group 4

technical data 15

technical information

 overview 14

W

wiring diagram 16